

# IMERA





# A-AV

## AUTOCLAVI VERTICALI VERTICAL PRESSURE TANKS RESERVOIRS VERTICALES A VESSIE

IMERA IMERA IMERA IMERA IMERA IMERA IMERA IMERA IMERA

### A-AS



5÷35 lt



P MAX 8 bar



P PRE 2 bar



EPDM



-10°C / +100°C

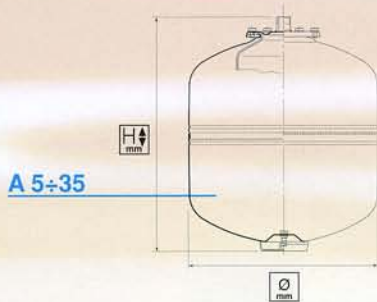

A 5÷35

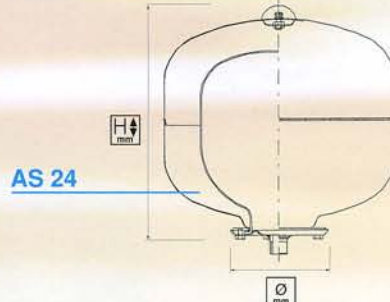

AS 24

COD	MOD	lt	Ø mm	H mm	mm	Ø1	Ø2	m³	mm
IV30051B1	A 5	5	160	305		3/4"		0,073	340x340x630 (8pc)
IV30081B1	A 8	8	200	320		3/4"		0,122	430x430x660 (8pc)
IV30121E1	A 12	12	280	315		3/4"		0,209	571x571x640 (8pc)
IV30181E1	A 18	18	280	395		3/4"		0,136	558x558x435 (4pc)
IV30242E1	A 24	24	280	490		1"		0,157	558x558x502 (4pc)
IV3S242E1	AS 24	24	350	350		1"		0,050	355x355x355
IV30352E1	A 35	35	365	460		1"		0,064	461x371x371

### AV



50÷1.000 lt



P MAX 10 bar



P PRE 2 bar



EPDM



-10°C / +100°C

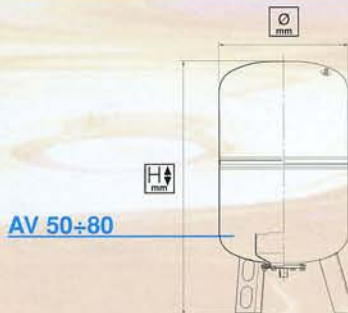

AV 50÷80

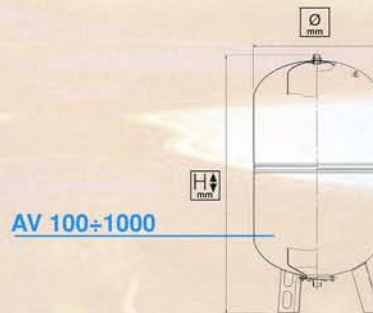

AV 100÷1000

COD	MOD	lt	Ø mm	H mm	mm	Ø1	Ø2	m³	mm
IV30502E1	AV 50	50	365	690		1"		0,096	701x366x374
IV30602E1	AV 60	60	365	805		1"		0,124	810x390x390
IV30802E1	AV 80	80	410	815		1"		0,143	821x411x422
IV31004E1	AV 100	100	495	805		1"	3/4"M-1/2"F	0,203	806x501x502
IV31504E1	AV 150	150	550	920		1"	3/4"M-1/2"F	0,257	1021x496x507
IV32005H1	AV 200	200	600	1020		1" 1/4	3/4"M-1/2"F	0,378	1024x606x607
IV33005H1	AV 300	300	650	1160		1" 1/4	3/4"M-1/2"F	0,504	1165x655x660
IV35005H1	AV 500	500	750	1410		1" 1/4	3/4"M-1/2"F	0,812	1415x755x760
IV37506H1	AV 750	750	800	1785		2"	3/4"M-1/2"F	pallet	80x120
IV3N107H1	AV 1000	1000	800	2100		2" 1/2	3/4"M-1/2"F	pallet	80x120

# AO



## AUTOCLAVI ORIZZONTALI HORIZONTAL PRESSURE TANKS RESERVOIRS HORIZONTAL A VESSIE

IMERA IMERA IMERA IMERA IMERA IMERA IMERA IMERA IMERA

### AO



18÷24 lt



P MAX 8 bar



P PRE 2 bar



EPDM



-10°C / +100°C

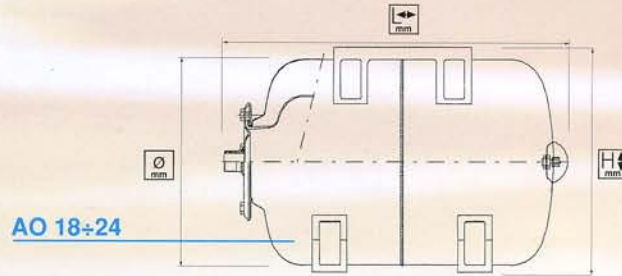

AO 18÷24

COD	MOD	lt	Ø mm	H mm	L mm	Ø1	Ø2	m³	mm
IV40182E1	AO 18	18	280	300	395	1"		0,136	568x608x502 (4pc)
IV40242E1	AO 24	24	280	300	490	1"		0,174	568x608x502 (4pc)

### AO



35÷300 lt



P MAX 10 bar



P PRE 2 bar



EPDM



-10°C / +100°C

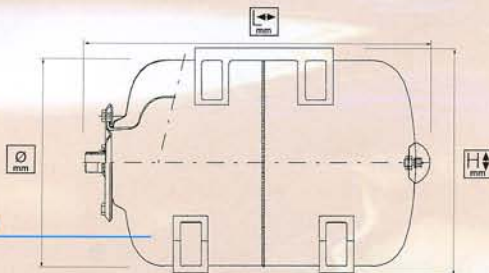

AO 35÷80

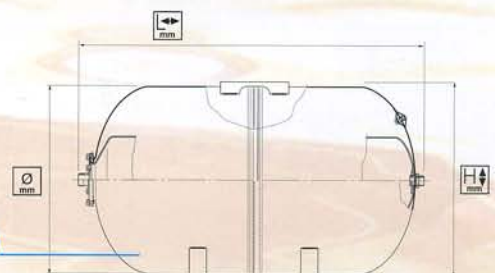

AO 100÷300

COD	MOD	lt	Ø mm	H mm	L mm	Ø1	Ø2	m³	mm
IV40352E1	AO 35	35	365	390	460	1"		0,067	456x371x392
IV40502E1	AO 50	50	365	390	565	1"		0,084	571x371x392
IV40602E1	AO 60	60	365	390	675	1"		0,097	675x370x385
IV40802E1	AO 80	80	410	440	690	1"		0,130	396x421x442
IV41004E1	AO 100	100	495	525	695	1"	3/4"M-1/2"F	0,184	696x501x527
IV41504E1	AO 150	150	550	580	800	1"	3/4"M-1/2"F	0,241	906x506x525
IV42005H1	AO 200	200	600	625	920	1"1/4	3/4"M-1/2"F	0,350	921x606x627
IV43005H1	AO 300	300	650	675	1090	1"1/4	4/4"M-1/2"F	0,504	1165x655x660

# X-VX-HX

**AUTOCLAVI INOX**  
**STAINLESS STEEL TANKS**  
**RESERVOIRS A VESSIE INOX**



**IMERA IMERA IMERA IMERA IMERA IMERA IMERA IMERA**

## X-VX



18÷200 lt



P MAX 8 bar



P PRE 2 bar



EPDM



-10°C / +100°C

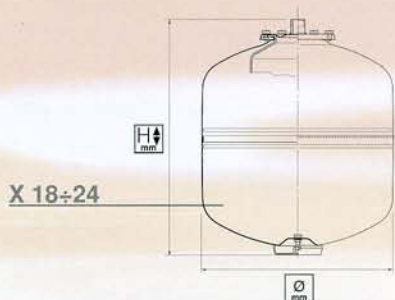

X 18÷24

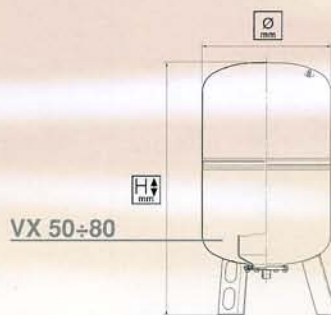

VX 50÷80

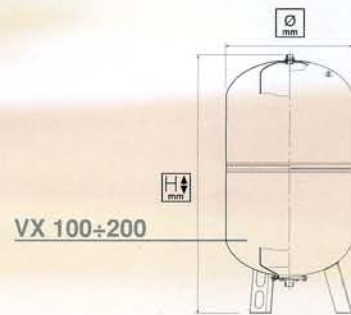

VX 100÷200

COD	MOD	lt	Ø mm	H mm	L mm	Ø1	Ø2	m³	mm
IV60182R1	X 18	18	280	395		1"		0,136	558x558x435 (4pc)
IV60242R1	X 24	24	280	490		1"		0,157	558x558x502 (4pc)
IV60502R1	VX 50	50	365	690		1"		0,096	701x366x374
IV60602R1	VX 60	60	365	805		1"		0,124	810x390x390
IV60802R1	VX 80	80	410	815		1"		0,150	821x411x422
IV61004R1	VX 100	100	495	805		1"	3/4"M-1/2"F	0,203	806x501x502
IV62004R1	VX 200	200	600	1020		1"	3/4"M-1/2"F	0,378	1026x606x607

## HX



18÷200 lt



P MAX 8 bar



P PRE 2 bar



EPDM



-10°C / +100°C

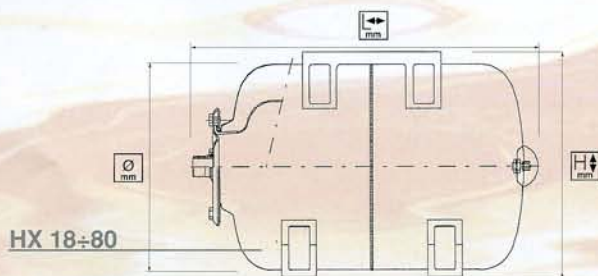

HX 18÷80

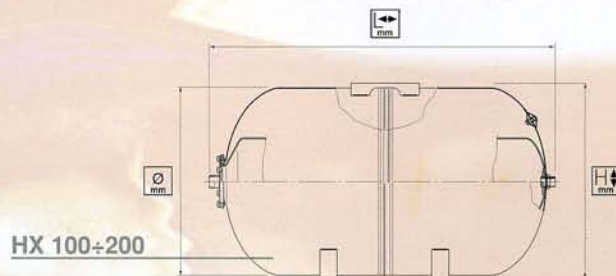

HX 100÷200

COD	MOD	lt	Ø mm	H mm	L mm	Ø1	Ø2	m³	mm
IV70182R1	HX 18	18	280	300	395	1"		0,136	568x608x502 (4pc)
IV70242R1	HX 24	24	280	300	490	1"		0,174	568x608x502 (4pc)
IV70502R1	HX 50	50	365	390	565	1"		0,084	571x371x392
IV70602R1	HX 60	60	365	390	675	1"		0,097	675x370x385
IV70802R1	HX 80	80	410	440	690	1"		0,130	696x421x442
IV71004R1	HX 100	100	495	525	695	1"	3/4"M-1/2"F	0,184	696x501x527
IV72004R1	HX 200	200	600	625	920	1"	3/4"M-1/2"F	0,350	921x606x627

# R-RV

**VASI DI ESPANSIONE A MEMBRANA INTERCambiabile**  
**EXPANSION VESSELS WITH INTERCHANGEABLE BLADDER**  
**VASES D'EXPANSION A VESSIE REPLACABLE**



**IMERA IMERA IMERA IMERA IMERA IMERA IMERA IMERA**

**R**



5÷50 lt



5 bar



1,5 bar



EPDM



-10°C / +100°C

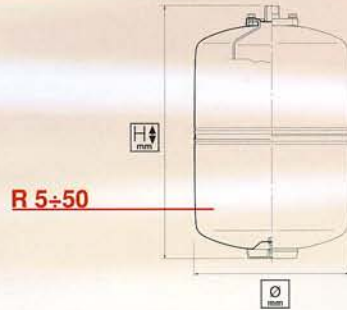

COD	MOD	lt	Ø mm	H mm	mm	Ø1	Ø2	m³	mm
IV50051A1	R 5	5	160	305		3/4"		0,073	340x340x630 (8pc)
IV50081A1	R 8	8	200	320		3/4"		0,122	430x430x660 (8pc)
IV50121A1	R 12	12	280	280		3/4"		0,210	571x571x640 (8pc)
IV50181A1	R 18	18	280	365		3/4"		0,140	558x558x435 (4pc)
IV50241A1	R 24	24	280	460		3/4"		0,160	558x558x502 (4pc)
IV50351D1	R 35	35	365	450		3/4"		0,070	461x371x377
IV50501D1	R 50	50	365	560		3/4"		0,082	581x371x377

**RV**



35÷1000 lt



5 bar



1,5 bar



EPDM



-10°C / +100°C

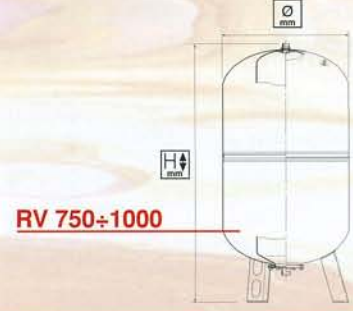
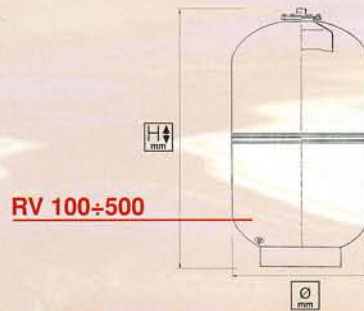
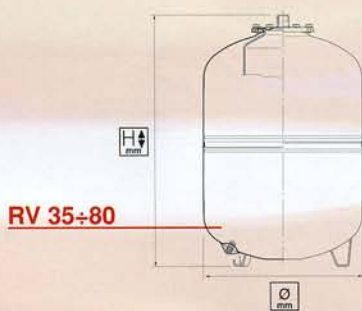

COD	MOD	lt	Ø mm	H mm	mm	Ø1	Ø2	m³	mm
IV5V351D1	RV 35	35	365	460		3/4"		0,070	461x371x377
IV5V501D1	RV 50	50	365	560		3/4"		0,082	581x371x377
IV50602D1	RV 60	60	365	685		1"		0,100	675x370x385
IV50802D1	RV 80	80	410	700		1"		0,130	706x416x425
IV51002D1	RV 100	100	495	795		1"		0,190	736x501x507
IV51502D1	RV 150	150	550	800		1"		0,240	936x501x507
IV52002D1	RV 200	200	600	900		1"		0,340	906x606x612
IV53005G1	RV 300	300	650	1100		1"1/4	3/4"M-1/2"F	0,504	1165x655x660
IV55005G1	RV 500	500	750	1320		1"1/4	3/4"M-1/2"F	0,812	1415x755x760
IV57506G1	RV 750	750	800	1785		2"	3/4"M-1/2"F	pallet	80x120
IV5N107G1	RV 1000	1000	800	2100		2"1/2	3/4"M-1/2"F	pallet	80x120



# M-MR-HR

VASI MULTIFUNZIONE

MULTIFUNCTION TANKS

RESERVOIRS MULTIFUNCIÓN A VESSIE

IMERA IMERA IMERA IMERA IMERA IMERA IMERA IMERA

## M-MR



5÷500 lt



P MAX 8 bar (5÷24 lt)  
10 bar (35÷500 lt)



P PRE 2 bar



EPDM



-10°C / +100°C

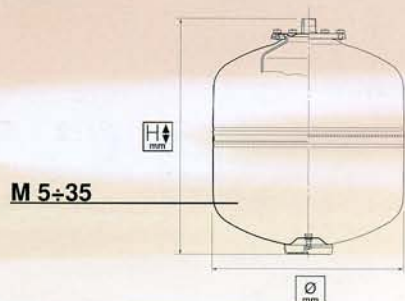

M 5÷35

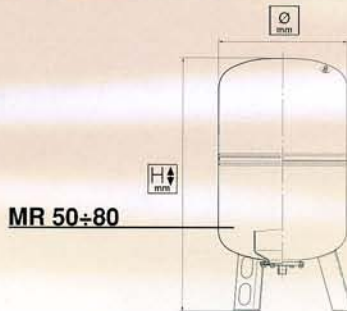

MR 50÷80

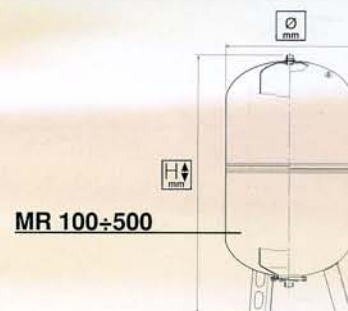

MR 100÷500

COD	MOD	lt	Ø mm	H mm	mm	Ø1	Ø2	m³	mm
IV10051C1	M 5	5	160	305		3/4"		0,073	340x340x530 (8pc)
IV10081C1	M 8	8	200	320		3/4"		0,122	430x430x660 (8pc)
IV10121F1	M 12	12	280	315		3/4"		0,209	571x571x640 (8pc)
IV10181F1	M 18	18	280	395		3/4"		0,136	558x558x435 (4pc)
IV10242F1	M 24	12	280	490		1"		0,157	558x558x502 (4pc)
IV10352F1	M 35	35	365	460		1"		0,065	461x371x377
IV10502F1	MR 50	50	365	690		1"		0,096	701x366x374
IV10602F1	MR 60	60	365	805		1"		0,114	810x390x390
IV10802F1	MR 80	80	410	815		1"		0,143	821x411x422
IV11004F1	MR 100	100	495	805		1"	3/4"M-1/2"F	0,203	806x501x502
IV11504F1	MR 150	150	550	920		1"	3/4"M-1/2"F	0,257	1021x496x507
IV12005L1	MR 200	200	600	1020		1"1/4"	3/4"M-1/2"F	0,241	1026x606x607
IV13005L1	MR 300	300	650	1160		1"1/4"	3/4"M-1/2"F	0,504	1165x655x660
IV15005L1	MR 500	500	750	1410		1"1/4"	3/4"M-1/2"F	0,812	1415x755x760

## HR



24÷300 lt



P MAX 8 bar (24 lt)  
10 bar (35÷300 lt)



P PRE 2 bar



EPDM



-10°C / +100°C

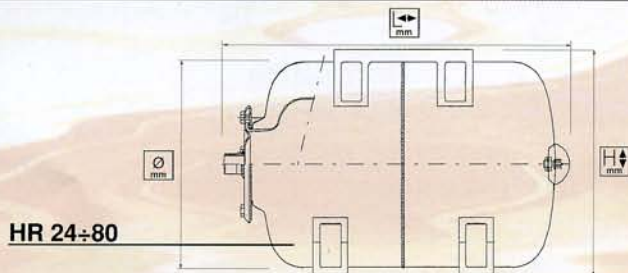

HR 24÷80

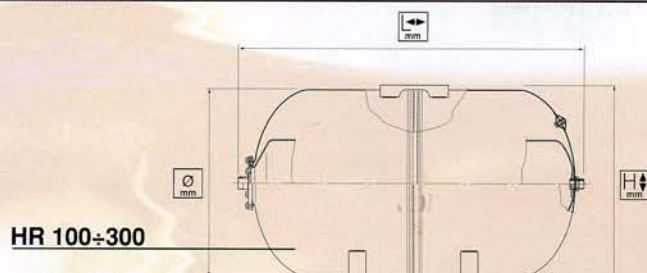

HR 100÷300

COD	MOD	lt	Ø mm	H mm	mm	Ø1	Ø2	m³	mm
IV20242F1	HR 24	24	280	300	490	1"		0,174	568x608x502 (4pc)
IV20352F1	HR 35	35	365	390	460	1"		0,067	456x371x392
IV20502F1	HR 50	50	365	390	565	1"		0,084	571x371x392
IV20602F1	HR 60	60	365	390	675	1"		0,124	810x390x390
IV20802F1	HR 80	80	410	440	690	1"		0,130	696x421x442
IV21004F1	HR 100	100	495	525	695	1"	3/4"M-1/2"F	0,184	696x501x527
IV22005L1	HR 200	200	600	625	920	1"1/4"	3/4"M-1/2"F	0,350	921x606x627
IV23005L1	HR 300	300	650	675	1090	1"1/4"	3/4"M-1/2"F	0,504	1165x655x660

# ACCESSORI

## ACCESSORI E RICAMBI ACCESSORIES SPAREPARTS ACCESSOIRES



IMERA IMERA IMERA IMERA IMERA IMERA IMERA IMERA IMERA

### Membrana - Bladder - Vassie



AUTOCLAVE PRESSURE TANK COD.	VASI ESP. EXP. VESSEL COD.	
AME99008A	AME99008V	5÷8
AME99024A	AME99024V	12÷18÷24
AME99050A	AME99050V	35÷50
AME99080A	AME99080V	60÷80
AME99150A	AME99150V	100÷150
AME99300A	AME99300V	200÷300
AME99750A	AME99750V	500÷750
AME99N10A	AME99N10V	1000

Membrana in Butile - su richiesta  
Butyl Bladder - on request  
Vessie en Butyl - sur demande

### Manometro - Pressure gauge - Manometre

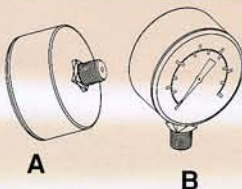

COD.	CONN.	BAR	
IMNAR5206	B	0÷6	50
IMNAR5212	B	0÷12	50
IMNAP5206	A	0÷6	50
IMNAP5212	A	0÷12	50

### Raccordo - Connection - Raccord

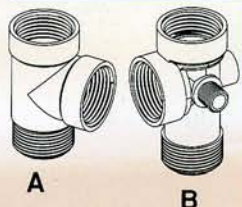

COD.	TYPE	Ø	
IRAC3V172	A	1"	71
IRAC5V172	B	1"	71
IRAC5V182	A	1"	82
IRAC5V192	B	1"	91

### Controflangia - Counterflange - Contrebride



COD.	D. mm	Ø	TYPE
IC095T34Z	95	3/4"	zn
IC095T01Z	95	1"	zn
IC095T34Z	145	3/4"	zn
IC145T34X	145	3/4"	inox
IC145T01Z	145	1"	zn
IC145T01X	145	1"	inox
IC260T14Z	260	1"1/4	zn

### Interruttore galleggiante Float switch - Interrupteur a flotteur



COD.	CABLE MT
IIGLCN005	0,5
IIGLCN050	5
IIGLCN100	10

### Pressostato - Pressure switch- pressostat

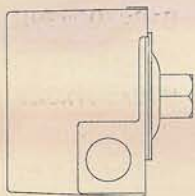

MOD	COD	BAR
IPRITCPM5	PM5	5
IPRSQFSG2	FSG2	6

### Flessibile MF - Flexible hole - Flexibles



COD.	Ø	
IFMFG0150	1"	500
IFMFG0160	1"	600
IFMFG0180	1"	800
IFMFG01N1	1"	1000

## SIMBOLI - SYMBOLS

**P  
MAX** Pressione massima di esercizio - Max Working pressure  
Pression max. d'exercice - Max. Betriebsdruck

**H  
mm** Altezza mm - Height mm  
Hauteur mm - Höhe mm

**P  
PRE** Pressione precarica - Precharge pressure  
Pression de pré charge - Vordruck

**L  
mm** Lunghezza mm - Length mm  
Longueur mm - Länge mm

**T** Temperatura - Temperature  
Température - Temperatur

**Ø1** Attacco - Connection  
Raccord - Gasfüllventil

**COD** Codice - Code  
Code - Code

**Ø2** Tirante - Support bladder  
Support vessie - Hartgelötet

**MOD** Modello - Model  
Modèle - Modell

**V  
m³** Volume - Volume  
Volume - Volumen

**lit** Capacità litri - Capacity liters  
Capacité litres - Fassungsvermögen liters

**mm** Imballo mm - Packaging mm  
Emballage mm - Verpackung mm

**Ø  
mm** Diametro mm - Diameter mm  
Diamètre mm - Durchmesser mm

**M** Membrana - Bladder  
Vessie - Membran

ООО "ФОНТЕЙН"

03680, Киев, пер. Радищева, 3  
тел./факс: (044) 507-12-20, 228-84-65  
e-mail: office@fontaine.com.ua"  
[office@fontaine.com.ua](mailto:office@fontaine.com.ua)  
<http://www.fontaine.com.ua>



# IMERA

IMERA

35010 CARMIGNANO DI BRENTA (PD) - Italy - Via Camazzole, 73

Tel. +39 0424 500936 - Fax +39 0424 500719

<http://www.imerait.it> - E-mail: info@imerait.it